

Monogram Aerospace Fasteners

DCB1000

PROCUREMENT SPECIFICATION FOR FASTENER INTERNALLY THREADED, SELF-LOCKING

DATE: 05-15-1985

REVISION:

	07-22-85	REV. A
	09-25-95	REV. B
ECN#1882	02-20-04	REV. C
ECN#4036	02-27-07	REV. D
ECN#4851	11-18-08	REV. E
DCN#15-0338	09-26-16	REV. F
DCN#17-0021	01-23-17	REV. G

APPROVED BY:

JERRY QUARESMA
ENGINEERING MANAGER

WARREN WHITEHEAD

VICE PRESIDENT OF QUALITY ASSURANCE

Monogram Aerospace Fasteners

TABLE OF CONTENTS

		PAGE
1.0	Scope - - - - -	3
2.0	Applicable documents - - - - -	3
3.0	General requirements - - - - -	5
	3.1 Qualifications - - - - -	5
	3.2 Design and construction - - - - -	5
	3.3 Metallurgical properties - - - - -	7
	3.4 Mechanical properties - - - - -	10
4.0	Quality assurance provisions - - - - -	12
	4.1 Responsibility for inspection- - - - -	12
	4.2 Classification of tests - - - - -	12
	4.3 Qualification tests - - - - -	13
	4.4 Quality Conformance tests - - - - -	13
	4.5 Test methods - - - - -	16
5.0	Preparation for delivery - - - - -	20
6.0	Notes - - - - -	20

TABLES

TABLE 1:	Depth Limits of Permitted Laps, Seams & Discontinuities - - - - -	8
TABLE 2:	DCB1070 Mechanical Properties - - - - -	11
TABLE 3:	DCB1077SP Mechanical Properties - - - - -	11
TABLE 4:	DCB1090 Mechanical Properties - - - - -	11
TABLE 5:	DCB1092 Mechanical Properties - - - - -	11
TABLE 6:	DCBP3F Mechanical Properties - - - - -	12
TABLE 7:	DCBP173V Mechanical Properties - - - - -	12
TABLE 8:	Qualification Tests - - - - -	14
TABLE 9:	Quality Conformance Tests - - - - -	14
TABLE 10:	Sampling for Installation Tests - - - - -	15
TABLE 11:	Sampling for Tensile, Preload and Double Shear - - - - -	15
TABLE 12A:	Classification of Dimensional Characteristics - - - - -	16
TABLE 12B:	Lot Inspection Requirements - - - - -	17
TABLE 12C:	Attribute Sampling for Dimensional Characteristics, Penetrant Inspection - - - - -	17

FIGURES

FIGURE 1:	Screw Thread Discontinuities - - - - -	9
FIGURE 1A:	Alpha Case Limitations - - - - -	9
FIGURE 2:	Grain Flow Lines - - - - -	10

Monogram Aerospace Fasteners

1.0 SCOPE & CLASSIFICATION:

1.1 Scope:

This specification defines the requirements for self-locking double flush, flush-protruding and double protruding fasteners.

1.2 Classification:

This specification covers fasteners manufactured from A-286, 6Al-4V and 6Al-6V-2Sn Titanium Alloys.

2.0 APPLICABLE DOCUMENTS:

2.1 The following publications of the issue in effect on date of invitation for bids form a part of this specification to the extend specified herein.

2.1.1 Specifications:

Federal:

PPP-B-566 Packaging and Packing for Overseas shipment -
Cartons, Folding, Paperboard.
PPP-B-676 Packaging and Packing for Overseas shipment - Boxes,
Metal Stayed, Paperboard.

Industry Standards

AMS4928, AMS4967 Titanium Alloy Bars and Forging (6Al-4V)
AMS4971 Titanium Alloy Bars, Forging and Rings (6Al-6V-2Sn)
AMS5731, AMS5732 Steel Bars, Forging and Rings Corrosion Resistant (A286)
AMS5737
AMS2759/4 Heat treatment of CRES Alloys
AMS-H-81200 Heat Treatment of Titanium and Titanium Alloys
AMS2700 Passivation Treatment for Corrosion Resistant Steel

TITLE	SPECIFICATION
PROCUREMENT SPECIFICATION FOR FASTENER INTERNALLY THREADED, SELF-LOCKING	DCB1000
REVISION: "G"	PAGE 3 OF 20 DATE: 01-23-17

Monogram Aerospace Fasteners

Military Standards:

- MIL-STD-105 Sampling Procedures and Tables for Inspection by Attributes.
- MIL-STD-129 Marking of Shipments.

ASTM and ANSI Standards:

- ASTM-E1417 Inspection, Penetrant Method of
- ASME B46.1 Surface Texture (Roughness, Waviness & Lag)

2.1.1 Monogram Engineering Standards

FASTENER DESCRIPTION	PART DESIGNATION
Fastener, Double Flush, Internally Threaded, Self-Locking, 100° Flush Head Pin with 100° Flush Head Nut. 6Al-4V Titanium, Constant Body and Nut Length within a Grip.	DCB1070
Fastener, Double Flush, Internally Threaded, Self-Locking, 100° Flush Head Pin with 100° Flush Head Nut. 6Al-4V Titanium, Constant Body and Nut length within a Grip. Extended Grip (3/4")	DCB1077SP
Fastener, Double Flush, Internally Threaded, Self-Locking, 100° Flush Head Pin with 100° Flush Head Nut. A-286 CRES, Constant Body and Nut Length within a Grip.	DCB1090
Fastener, Double Flush, Internally Threaded, Self-Locking, 100° Flush Head Pin with 100° Flush Head Nut. A-286 CRES, Variable Body and Nut Length within a Grip.	DCB1092
Fastener, Flush Head and Protruding Head, Internally Threaded, Self-Locking, Protruding Head Pin (6Al-6V-2Sn) with 130° Flush Head Nut (6Al-4V) Titanium.	DCBP3F-V06
Fastener, Flush Head and Protruding Head, Internally Threaded, Self-Locking, Protruding Head Pin (6Al-6V-2Sn) with 130° Flush Head Nut (6Al-4V) Titanium.	DCBP173V

2.1.3 Monogram Specification: DCB1001 Installation and Inspection Specification

TITLE	SPECIFICATION
PROCUREMENT SPECIFICATION FOR FASTENER INTERNALLY THREADED, SELF-LOCKING	DCB1000
REVISION: "G"	PAGE 4 OF 20 DATE: 01-23-17

Monogram Aerospace Fasteners

3.0 GENERAL REQUIREMENTS:

3.1 Qualification:

The fasteners furnished under this specification shall be a product which has been tested according to and has passed the qualification tests specified herein. No significant changes in dimensions, material, or manufacturing procedures are permitted without re-qualification.

3.1.1 Component Parts:

The fastener shall basically be constructed of two or three components defined as follows:

- Nut: Consists of an external shank and a manufactured head. The nut is internally threaded.
- Screw: Consists of a manufactured head, wrenching flats and partially or fully threaded shank.
- Body: Consists of a head and shank. The body is smooth bored.
- Washer: For DCBP173V Fastener, to prevent damage to the composite structure during installation.

3.1.2 Material:

Material used in the manufacture of each component (nut, body and screw) of the fastener shall be as specified below:

- Type I: Nut, Screw, and Body -Heat resistant steel (A-286) per the chemical requirements of AMS5731, AMS5732 or AMS5737
- Type II: Nut, Screw, and Body -Titanium Alloy (6Al-4V) per AMS4928 or AMS4967.
- Type III: Nut and Body -Titanium Alloy (6Al-4V) per AMS4928 or AMS4967. Screw – Titanium Alloy (6Al-6V-2Sn) per AMS4971. Washer - Cp Titanium per Mil-T-9046/7 or equiv.

3.2 Design & Construction:

The fastener shall be of two (2) or three (3) piece construction and may be furnished as an integral assembly or as separate components. The fastener configuration and all dimensions shall conform to the applicable standard drawing. All dimensions are to be met exclusive of lubrication.

3.2.1 Component Heads: The manufactured heads of nut and screw components shall be forged. The body component may be forged or machined.

3.2.2 Threads:

The thread on the screw and in the nut shall be suitable for installation of the fastener. Threads shall be left-hand or right hand. The screw threads shall be fully formed by a single rolling process.

Type I Screws: shall be thread rolled before thermal processing.

Type II & III Screws: shall be thread rolled after thermal processing.

TITLE

SPECIFICATION

PROCUREMENT SPECIFICATION FOR FASTENER

DCB1000

INTERNALLY THREADED, SELF-LOCKING

PAGE 5 OF 20

REVISION: "G"

DATE: 01-23-17

Monogram Aerospace Fasteners

3.2.3 Finish:

Components fabricated from corrosion resistant steel shall be passivate per AMS2700, exhibiting a clean surface free of oxides and metal contaminants. Surfaces of components fabricated from Titanium, which permits Alpha Case as per Fig. 1A, shall not be subject to finish requirements. Finishes shall be as specified on Monogram Standards drawings.

3.2.4 Lubricant:

Lubricant may be used on any component to improve driving. Production lots with lubricants other than those used on original qualification testing shall be retested to assure compliance with the installation requirements of Paragraph 3.4.1. Core-bolts shall be dry film lube per AS5272. Assemblies and/or components may be further lubricated with dry film lube per AS5272, paraffin wax and/or cetyl alcohol per MIL-L-87132 as required for performance.

3.2.5 Dimensions

- a) Dimensions shall be in accordance with the Monogram part standard
- b) Except as otherwise noted on the standard, all dimensions shall be in inches and shall apply after application of finish coating and before lubrication.
- c) For inspection lot sampling, see Table 11C and for qualification sampling see Table 9.

3.2.6 Surface Texture:

- a. Surface texture shall be in accordance with the Monogram part standard.
- b. Except as otherwise noted on the standard, surface texture requirements apply before coating and lubrication. Fastener manufacture shall inspect subsequent to all forming operations (heading, thread roll, etc.), machining and grinding operations and prior to application of finish coating and/or lubricant. (Optionally, surface texture may be destructively inspected with the finish coating and lubricants removed provided the removal method does not alter the original surface texture).
- c. Test per ANSI/ASME B46.1 by fingernail comparison with standard G.E. surface texture specimens. In case of controversy, a profile-meter may be used for checking surface texture if surface is accessible.
- d. For inspection lot sampling see Table 11B, and for qualification sampling see Table 9.

3.2.7 Part Identification:

- a. Nuts and Screws shall be marked for identification in accordance with the Monogram Standard Drawing.
- b. Inspect by visual examination and depth or height measurement. Part marking shall be legible with 2X magnification or less. Depth of the head marking to be measured from undisturbed surface. Sampling for depth measurement of part marking shall be per Table 11B.

TITLE	SPECIFICATION
PROCUREMENT SPECIFICATION FOR FASTENER	DCB1000
INTERNALLY THREADED, SELF-LOCKING	PAGE 6 OF 20
REVISION: "G"	DATE: 01-23-17

Monogram Aerospace Fasteners

3.3 Metallurgical Properties:

3.3.1 Hydrogen and Oxygen Content:

Titanium components shall be analyzed for hydrogen content using procedures and equipment capable of accuracy of 0.0010 percent (10 PPM) when examined per paragraph 4.5.4.3
Lubricant shall be removed before testing. Test for oxygen is not mandatory.

3.3.2 Cracks:

Fastener components shall be free of cracks in any direction or location. A crack is defined as a clean crystalline break passing through the grain boundary with or without the inclusion of foreign elements.

3.3.3 Discontinuities:

Discontinuities are permitted except as specified below, provided they do not exceed the depths specified in Table 1.

3.3.3.1 Bodies:

Permissible discontinuities shall be as per Table 1 and Figure 1A.

3.3.3.2 Screws:

Permissible discontinuities shall be as per Table 1, Figure 1 and Figure 1A.
Discontinuities in threads are considered as laps only if they appear in two or more consecutive pitches of the thread profile in longitudinal section in the same location.

3.3.3.3 Nuts:

Permissible discontinuities shall be as per Table 1 and Figure 1A.

TITLE	SPECIFICATION
PROCUREMENT SPECIFICATION FOR FASTENER INTERNALLY THREADED, SELF-LOCKING	DCB1000
REVISION: "G"	PAGE 7 OF 20 DATE: 01-23-17

Monogram Aerospace Fasteners

TABLE 1
DEPTH LIMITS OF PERMITTED LAPS, SEAMS & DISCONTINUITIES

COMPONENT	LOCATION	PERMISSIBLE DISCONTINUITIES	DIAMETER DASH NUMBER			
			-05,-06	-08	-10	-12
BODY	HEAD-TO-SHANK FILLET AND HEAD BEARING SURFACE	NONE	---			
	* NON-BEARING SURFACE OF HEAD	LAPS, SEAMS, INCLUSIONS, GOUGES, TOOL MARKS	.012			
	ALL OTHER LOCATIONS		.008	.010		
SCREW	HEAD-TO-SHANK FILLET, ROOT OF THREADS HEAD BEARING SURFACE	NONE	---			
	NON-BEARING SURFACE OF HEAD	LAPS, SEAMS, INCLUSIONS, GOUGES, TOOL MARKS	.010			
	STEM BREAK NECK AREA, ALL OTHER LOCATIONS*		.002	.004	.005	
NUT	ANY	LAPS, SEAMS, INCLUSIONS, GOUGES, TOOL MARKS	.008	.010	.010	.012

*The pintail portion of the screw up to the stem break area are excluded from discontinuity requirements.

3.3.4 Metallurgical Condition:

3.3.4.1 Grinding Burns:

Components shall be examined per Paragraph 4.5.4 for grinding burns after grinding but prior to fillet or thread rolling operations. Grinding burns are not permitted on the shank, head-to-shank fillet, external threads, or bearing surface of nut or screw. For titanium parts, localized areas exhibiting an alpha case are considered indicative of grinding burns and are unacceptable. Exception: Titanium components may have partial or full microstructure change to depth of .003" maximum on non-bearing surface of head only (Figure 1A).

TITLE

SPECIFICATION

PROCUREMENT SPECIFICATION FOR FASTENER

DCB1000

INTERNALLY THREADED, SELF-LOCKING

PAGE 8 OF 20

REVISION: "G"

DATE: 01-23-17

Monogram Aerospace Fasteners

FIGURE 1
SCREW THREAD DISCONTINUITIES

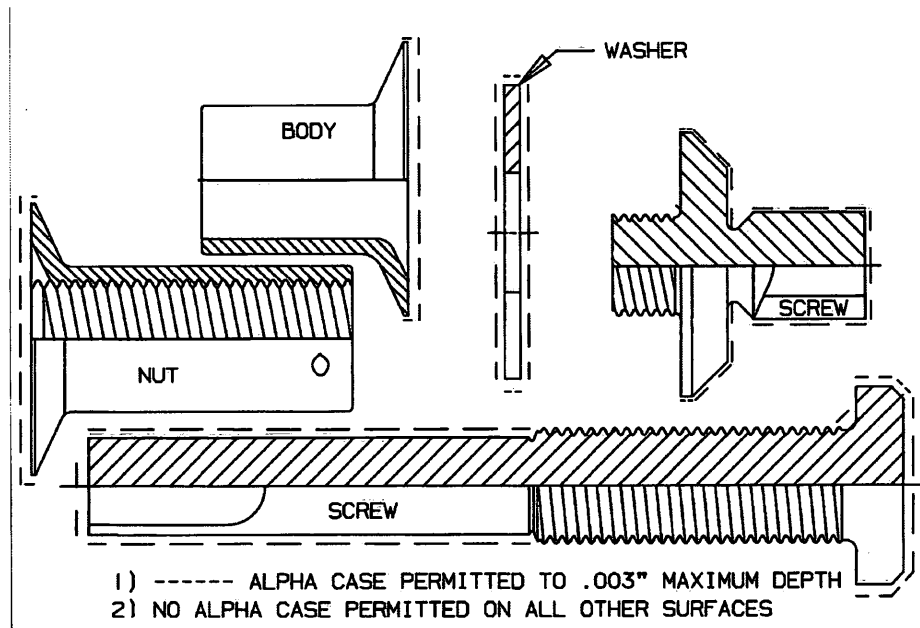
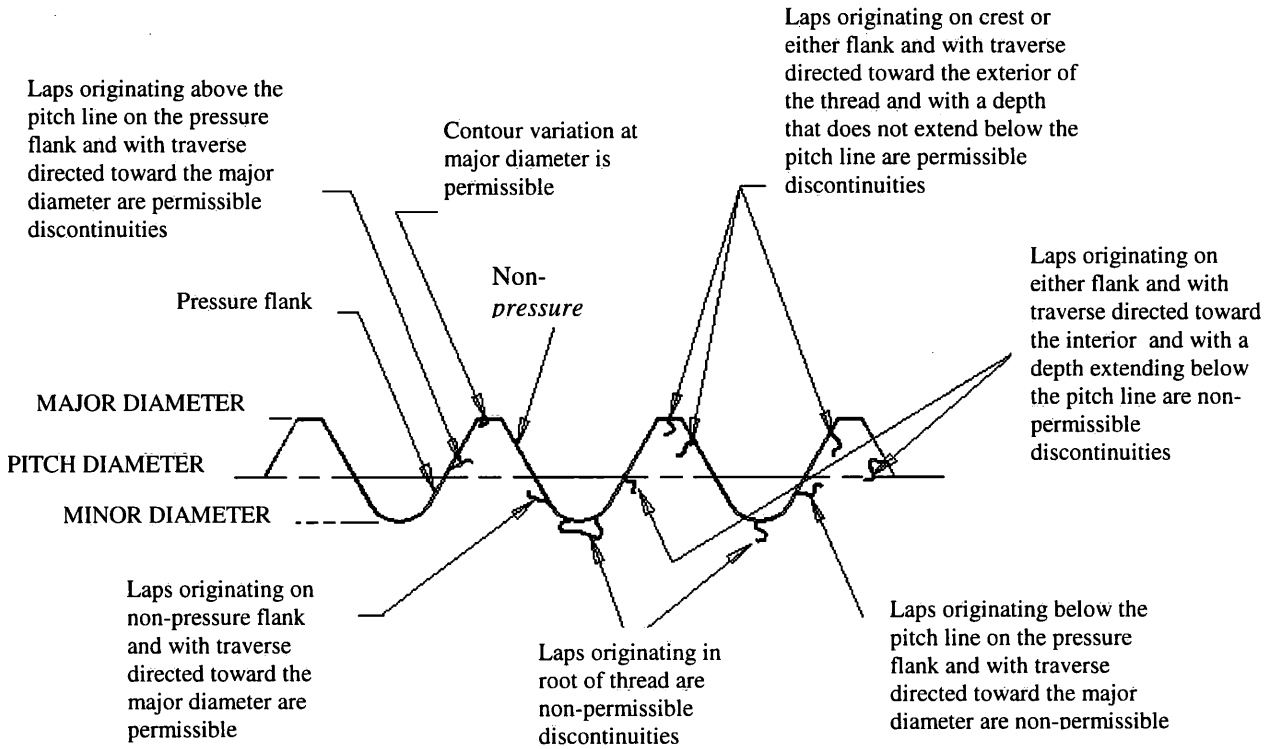

FIGURE 1A
ALPHA CASE LIMITATIONS

TITLE	SPECIFICATION
PROCUREMENT SPECIFICATION FOR FASTENER	DCB1000
INTERNALLY THREADED, SELF-LOCKING	PAGE 9 OF 20
REVISION: "G"	DATE: 01-23-17

Monogram Aerospace Fasteners

3.3.4.2 Microstructure:

When examined per Paragraph 4.5.3, Titanium components shall show no evidence of inclusions, alloy segregation, or surface contamination. Titanium components shall be free of Widmanstatten or acicular (basketweave) structure. Titanium components' microstructure shall not show evidence of alpha case in excess of the limitations of Figure 1A.

3.3.4.3 Grain Flow:

The grain flow of nut and screw heads and of screw external threads shall be uniform when examined per Paragraph 4.5.3.

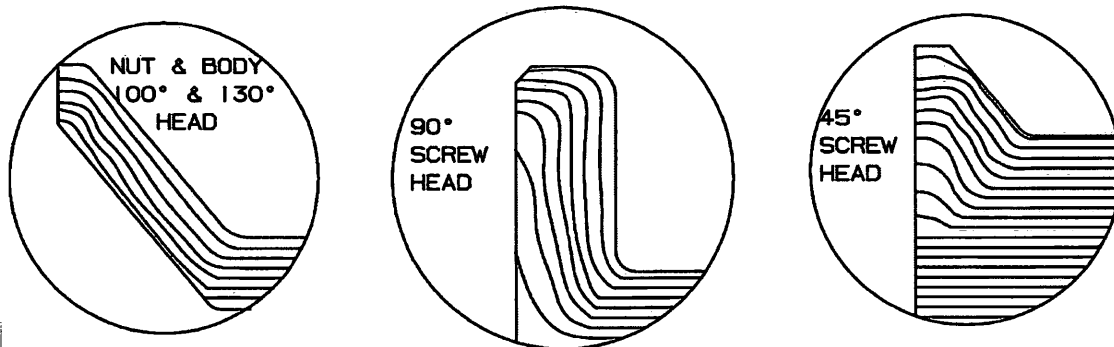

FIGURE 2 GRAIN FLOW LINES

3.4 Mechanical Properties:

3.4.1 Installation:

Fasteners shall drive consistently when installed and examined in accordance with Par. 4.5.4.

3.4.2 Double Shear Strength:

The double shear strength of the fastener shall be as specified in Table 3 thru Table 8, when tested as specified in Paragraph 4.5.5.

3.4.3 Tensile Strength:

The tensile strength of the driven fastener shall be as specified in Table 3 thru Table 8, when tested as specified in Paragraph 4.5.6.

3.4.4 Tension Preload:

The driven fastener shall develop tension preload values within the range specified in Table 3 thru Table 8, when tested as specified in Paragraph 4.5.7.

3.4.5 Locking Torque:

The installed fasteners shall develop locking torque values equal to or greater than the minimum required torque per Table 3 thru Table 8, when tested in accordance with Paragraph 4.5.8.

TITLE

SPECIFICATION

PROCUREMENT SPECIFICATION FOR FASTENER

DCB1000

INTERNALLY THREADED, SELF-LOCKING

PAGE 10 OF 20

REVISION: "G"

DATE: 01-23-17

Monogram Aerospace Fasteners

TABLE 2
DCB1070 - MECHANICAL PROPERTIES

DIA. DASH NO.	NOM. DIA.	LOCKING TORQUE (IN-LBS) MIN.	SEATING TORQUE IN/LBS MIN	DOUBLE SHEAR STRENGTH 75 KSI FSU (LBS) MIN.	TENSILE STRENGTH (LBS) MIN.	TENSILE PRELOAD (LBS)	
-06(-)	3/16	1.5	6	4600	1400	280	980
-08(-)	1/4	2.5	10	7900	2100	420	1470
-10(-)	5/16	3.5	20	11350	3600	720	2520
-12(-)	3/8	4.0	30	16450	5600	1120	3920

TABLE 3
DCB1077SP - MECHANICAL PROPERTIES

DIA. DASH NO.	NOM. DIA.	PREVAILING TORQUE (IN-LBS) MIN.	SEATING TORQUE IN/LBS MIN	DOUBLE SHEAR STRENGTH 75 KSI FSU (LBS) MIN.	TENSILE STRENGTH (LBS) MIN.	TENSILE PRELOAD (LBS)	
						MIN	MAX
-06(-)	3/16	1.5	6	4600	1400	280	840
-08(-)	1/4	2.5	10	7900	2100	420	1260

TABLE 4
DCB1090 - MECHANICAL PROPERTIES

DIA. DASH NO.	NOM. DIA.	PREVAILING TORQUE (IN-LBS) MIN.	SEATING TORQUE IN/LBS MIN	DOUBLE SHEAR STRENGTH 85 KSI FSU (LBS) MIN.	TENSILE STRENGTH (LBS) MIN.	TENSILE PRELOAD (LBS)	
						MIN	MAX
-06(-)	3/16	1.5	6	5420	1400	280	980
-08(-)	1/4	2.5	10	9000	2100	420	1470
-10(-)	5/16	3.5	20	12000	3600	720	2520
-12(-)	3/8	4.0	30	19500	5600	1120	3920

TABLE 5
DCB1092 - MECHANICAL PROPERTIES

DIA. DASH NO.	NOM. DIA.	PREVAILING TORQUE (IN-LBS) MIN.	SEATING TORQUE IN/LBS MIN	DOUBLE SHEAR STRENGTH 75 KSI FSU (LBS) MIN.	TENSILE STRENGTH (LBS) MIN.	TENSILE PRELOAD (LBS)	
						MIN	MAX
-05(-)	5/32	1.0	4	3150	900	180	900

TITLE

SPECIFICATION

PROCUREMENT SPECIFICATION FOR FASTENER

DCB1000

INTERNALLY THREADED, SELF-LOCKING

PAGE 11 OF 20

REVISION: "G"

DATE: 01-23-17

Monogram Aerospace Fasteners

TABLE 6
DCBP3F - MECHANICAL PROPERTIES

DIA. DASH NO.	NOM. DIA.	PREVAILING TORQUE (IN-LBS) MIN.	SEATING TORQUE IN/LBS MIN	DOUBLE SHEAR STRENGTH 90 KSI FSU (LBS) MIN.	TENSILE STRENGTH (LBS) MIN.	TENSILE PRELOAD (LBS)	
						MIN	MAX
-V06-()	3/16	1.5	6	5400	1600	450	1100

TABLE 7
DCBP173V - MECHANICAL PROPERTIES

DIA. DASH NO.	NOM. DIA.	PREVAILING TORQUE (IN-LBS) MIN.	SEATING TORQUE IN/LBS MIN	DOUBLE SHEAR STRENGTH 90 KSI FSU (LBS) MIN.	TENSILE STRENGTH (LBS) MIN.	TENSILE PRELOAD (LBS)	
						MIN	MAX
-06-()	3/16	1.5	6	5400	1600	500	1100
-08-()	1/4	2.5	10	9400	3000	900	1600
-10-()	5/16	3.5	20	13500	5000	1500	2400
-12-()	3/8	4.0	30	19600	7000	2000	2900

4.0 QUALITY ASSURANCE PROVISIONS:

4.1 Responsibility for Inspection:

Unless, otherwise specified in the contract or purchase order, the supplier is responsible for the performance of all inspection requirements as specified herein. Except as otherwise specified in the contract or order, the supplier may use his own or any other facilities suitable for the performance of the inspection requirements specified herein.

4.2 Classification of Tests:

Inspection and testing of fasteners shall be classified as follows:

4.2.1 Qualification Tests:

Qualification tests are those performed on samples of fasteners in order to determine that they meet all the requirements of this specification, as specified in Table 8.

4.2.2 Quality Conformance Tests:

Quality conformance tests are those performed on each lot of fasteners manufactured to this specification. Their purpose is to insure the maintenance of quality on a lot-to-lot basis. The results of quality conformance tests shall be recorded for each inspection lot.

Monogram Aerospace Fasteners

4.3 Qualification Tests: (Qualification tests shall consist of all tests of this specification listed in Table 8.)

4.3.1 Sampling:

Qualification test samples shall consist of fasteners of each diameter, for which qualification is desired, in quantities indicated in Table 8.

4.3.2 Certified Test Report:

The manufacturer shall maintain on file a certified test report showing that the manufacturer's product satisfactorily conforms to this specification. The test report shall include, as minimum, actual results of each of the tests specified herein in their order of appearance. A copy of the test report shall be made available to the purchaser upon request.

4.4 Quality Conformance Tests:

(Quality conformance testing shall consist of all tests listed in Table 9.)

4.4.1 Inspection Lot:

An assembly lot shall consist of fully assembled fasteners of the same head configuration, diameter, grip length and heats of material. The assemblies and their components shall be manufactured under the same conditions and heat treated in the same manner.

4.4.2 Sampling:

Samples shall be selected at random from each lot in accordance with Table 9. The same samples may be used for two or more tests, provided selection of random samples is maintained and known characteristics of the samples are not used to influence the integrity of the test results.

4.4.3 Acceptance Criteria:

All samples must meet the requirements of Section 3 within the acceptance limits of Table 9.

TITLE

SPECIFICATION

PROCUREMENT SPECIFICATION FOR FASTENER

DCB1000

INTERNALLY THREADED, SELF-LOCKING

PAGE 13 OF 20

REVISION: "G"

DATE: 01-23-17

Monogram Aerospace Fasteners

TABLE 8
QUALIFICATION TESTS

TEST	REQMT PARA.	METHOD PARA.	SAMPLE SIZE			TOTAL QUAL. SAMPLE SIZE	MIN GRIP LENGTH	NUMBER OF DEFECTS ALLOWED
			GRIP CONDITION					
			MIN	NOM	MAX			
Dimensions, Head Marking, Surface Texture	3.2.5 3.2.6 3.2.7	-	-	-	-	All Qual. Sample	-	0
Discontinuities	3.3.3	-	-	-	-		-	0
Hydrogen Content	3.3.1	-	-	-	-	1	-	0
Metallurgical Condition	3.3.4	4.5.3	-	-	-	5	-	0
Double Shear Strength	3.4.2	4.5.5	-	-	-	5	②	0
Tensile Strength	3.4.3	4.5.6	5	-	5	10	2 D	0
Tensile Preload	3.4.4	4.5.7	5	-	5	10	2 D	0
Thread Locking Torque	3.4.5	4.5.8	-	-	5	5	-	0
Installation	3.4.1	4.5.4	25	-	25	50	-	0
Hardness	4.5.3	4.5.3.1	-	-	-	5	-	0

① One major defect and two minor defects allowed. See par.4.5.4

② Two and one-half diameter for flush head fastener. Two diameters for protruding head fastener.

TABLE 9
QUALITY CONFORMANCE TESTS

TEST	REQMT PARA.	METHOD PARA.	SAMPLE SIZE	ACCEPTANCE LIMITS
Examination	3.2	4.5.1	Refer to Table 12B	Per Table 12C
Hydrogen content	3.3.1	4.5.3.3	1 (Titanium only)	②
Cracks & Discontinuities	3.3.2 3.3.3	4.5.2	Refer to Table 12B	Per Table 12C
Metallurgical Condition	3.3.4	4.5.3	6	0 Defective
Installation	3.4.1	4.5.4	Per Table 10	Per Table 10
Double Shear Strength	3.4.2	4.5.5	Per Table 11	0 Defective
Tensile Strength	3.4.3	4.5.6		
Tension Pre-load	3.4.4	4.5.7		
Thread Locking Torque	3.4.5	4.5.8	5 samples for lots of 1200 or less. 8 sample for lots over 1200	
Hardness (A-286 only)	4.5.3	4.5.3.1	5	

② If hydrogen content exceeds the requirements, retest five additional samples. If any one from the additional sample exceeds the requirements, reject the lot.

TITLE

SPECIFICATION

PROCUREMENT SPECIFICATION FOR FASTENER

DCB1000

INTERNALLY THREADED, SELF-LOCKING

PAGE 14 OF 20

REVISION: "G"

DATE: 01-23-17

Monogram Aerospace Fasteners

**TABLE 10
SAMPLING FOR INSTALLATION TESTS**

LOT SIZE	SAMPLE SIZE ①	ACCEPT	REJECT
1 Thru 1300	8	0	1
1301 Thru 3200	10	0	1
3,201 Thru 8000	14	0	1
8001 and up	24	0	1
QUALIFICATION	100	2	3

① One half of the noted sample size is tested in each of maximum and minimum grip condition with clearance hole.

**TABLE 11
SAMPLING FOR TENSILE, PRELOAD AND DOUBLE SHEAR**

LOT SIZE	SAMPLE SIZE	ACCEPTANCE NUMBER
UP TO 1300 OR INITIAL QUALIFICATION	5	ZERO DEFECTS
1301 - 3200	7	
3201 - 8000	10	
8001 - 22000	15	
22001 AND UP	25	

4.4.4 Manufacturer's Inspection Report:

Each inspection lot shall be identified by a number to be included in the package marking. Each inspection lot of fasteners shall be accompanied by a copy of the manufacturer's inspection report, signed by an authorized representative of the manufacturer. This report shall state that the fasteners are from an assembly lot which was manufactured, inspected and accepted in accordance with the requirements of this specification. This report shall identify the part number, assembly lot number, and components' lot numbers; and shall include, as a minimum, the actual test values for double shear, tensile strength, tension preload, fatigue, and locking torque. This report shall also state that material chemistry, metallurgical examinations, and installation criteria were found to be acceptable and conformed to the appropriate specifications.

4.4.5 Exception to Quality Conformance Inspection:

Mechanical properties for fasteners with grip lengths too short to be tested in the conventional manner may be verified by hardness test (A-286 SS) or Heat Treatment record (Titanium).

Monogram Aerospace Fasteners

4.5 Test Methods:

4.5.1 Examination:

Each of the sample fasteners selected at random in accordance with Table 8 or Table 9, shall be examined for conformance to the requirements for dimensions, concentricity, roundness, protective treatment, and marking. These examinations shall be accomplished using optical aids or special gages to insure compliance with this specification.

4.5.1.1 Classification of Defects:

All dimensional characteristics are considered defective when out of tolerance. The classification of defects shall be per Table 12A and Table 12C.

**TABLE 12A
CLASSIFICATION OF DIMENSIONAL CHARACTERISTICS**

CLASSIFICATION	CHARACTERISTIC
Class A	Shank diameter (body & nut) Inside diameter (body & nut) Grip length (body & nut) Squareness between head and shank (body & nut) Under head bearing surface to shank for protruding head Top of head to shank for flush head Head angle (flush head body & nut) Concentricity of head and shank (body & nut) Identification (body & nut) Head protrusion (flush head body & nut)
Class B	Radius, Head to Shank Fillet (body & nut) Surface roughness (assembly) Burrs and tool marks (assembly) Lubrication (assembly) Overall Length (assembly) Head diameter (flush head body & nut) Head height (protruding head body & nut) Concentricity of shank to head (screw) All other dimensions
Class C	Presence of threads (screw and nut) Presence of locking indentations or crimp (nut) Presence of driving provisions (screw) Presence of recesses in head (nut)

TITLE

SPECIFICATION

PROCUREMENT SPECIFICATION FOR FASTENER

DCB1000

INTERNALLY THREADED, SELF-LOCKING

PAGE 16 OF 20

REVISION: "G"

DATE: 01-23-17

Monogram Aerospace Fasteners

4.5.2 Cracks & Discontinuities:

Components shall be fluorescent penetrant inspected per ASTM-E1417. Apply penetrant inspection before plating and lubrication or with plating and lubrication removed. Fasteners shall not be marked for identification of penetrant inspection. If indications are apparent, representative samples showing the indications shall be sectioned, mounted, and microscopically examined at 100X magnification for conformance to Paragraphs 3.3.2. and 3.3.3. A qualified technician shall decide the amount of examination required to determine whether discontinuities exceed Table 1 depth limits.

TABLE 12B
LOT INSPECTION REQUIREMENTS

CHARACTERISTIC	REQUIREMENTS AND TEST METHODS SECTION	LOT SAMPLING REQUIREMENTS
Dimensions	3.2	Sample per Table 12C, with classification of Characteristics per Table 12A
Surface Texture	3.2	Sample per Table 12C, reduced sampling.
Part Identification	3.2	Sample per Table 12C, reduced sampling.
Penetrant Inspection	3.3	Sample per Table 12C, Full Sampling, Class A. Increase to 100% inspection for screening if indications can be directly related to discontinuities exceeding limits of Table I.
Packaging	5.1	Sample per Table 12C, Full Sampling, Class A
Package Marking	5.2	Sample per Table 12C, Full Sampling, Class A

TABLE 12C
ATTRIBUTE SAMPLING PLAN FOR DIMENSIONAL CHARACTERISTICS, PENETRANT INSPECTION AND PACKING

Lot Size	FULL SAMPLING			REDUCED SAMPLING
	CLASS A SAMPLE SIZE	CLASS B SAMPLE SIZE	CLASS C SAMPLE SIZE	CLASS A & B SAMPLE SIZE
Under 26	9	5	13	1
26 – 50	10	6	15	1
51 – 90	13	8	19	2
91 – 150	15	10	23	2
151 – 280	19	13	30	2
281 – 500	24	16	42	3
501 – 1200	31	19	51	3
1201 – 3200	35	23	59	3
3201 – 10,000	45	28	77	4

- 1) The acceptance number in all cases is zero defects.
- 2) For packaging requirements lot size refer to number of bags per shipment. Bag quantities less than sample size noted are subject to 100% inspection

4.5.3 Metallurgical Conditions:

TITLE	SPECIFICATION
PROCUREMENT SPECIFICATION FOR FASTENER	DCB1000
INTERNALLY THREADED, SELF-LOCKING	PAGE 17 OF 20
REVISION: "G"	DATE: 01-23-17

Monogram Aerospace Fasteners

4.5.3.1 Hardness:

Hardness testing in accordance with NASM1312, Test 6 is applicable to A-286 CRES screw, body and nut components.

The hardness test shall be by Rockwell C scale or 45N scale at three places on suitably prepared surfaces of unmounted components or by Rockwell 30N or 45N at three places on specimens firmly mounted and polished. Rockwell 15N may be used only when components are too small to permit use of the Rockwell 30N impressions. Hardness scales other than those referenced above may be used with the conversions of ASTM E140 being applicable. Sampling size as per Table 9 or Table 10. Acceptance criteria as per applicable component drawing.

4.5.3.2 Metallurgical Condition-Titanium Components:

Five (5) specimens out of each heat treat lot of titanium components, shall be longitudinally sectioned, mounted and microscopically examined for conformance to Section 3.3.4

4.5.3.3 Hydrogen Content-Titanium Components:

Titanium components shall be analyzed for hydrogen content using procedures and equipment capable of accuracy of 0.0010 percent (10 PPM). Lubricant shall be removed before testing.

6Al-4V Titanium components shall not have hydrogen content exceeding .0125 percent (125 PPM) and 6Al-6V-2Sn Titanium components shall not have hydrogen content exceeding .015 percent (150 PPM). Titanium components shall not have oxygen content exceeding .2 percent (2000 PPM). Test for oxygen is not mandatory.

4.5.4 Installation Requirements:

The fasteners shall be driven in hardened steel plates (Rc 46 Min.) The fasteners shall be driven in both the maximum grip +0.002/-0.000 inch and the minimum grip +0.000/-0.002 inch conditions. The installation hole sizes shall be per applicable standard drawing and the countersinks for flush head fasteners shall be equal to the fasteners maximum theoretical sharp head diameter \pm 0.003 inch. The screw break-off limits shall be measured for conformance to the applicable standard drawing. The seating torque shall be checked on the minimum grip samples only.

Sampling for conformance installation tests shall be in accordance with Table X.

The samples for initial qualification shall consist of 50 fasteners with a grip length of between three and four times the nominal fastener diameter.

Major defects are screw failures, loose fasteners (as determined by torque test) and nut head failures. Minor defects are screw break-off and pre-load value outside of limits. Break-off limits and torque values shall be as specified in Table 3 thru Table 8 and applicable standard drawing.

TITLE

SPECIFICATION

PROCUREMENT SPECIFICATION FOR FASTENER

DCB1000

INTERNALLY THREADED, SELF-LOCKING

PAGE 18 OF 20

REVISION: "G"

DATE: 01-23-17

Monogram Aerospace Fasteners

4.5.5 Double Shear Strength:

Double Shear Strength tests shall be performed in accordance with NASM1312, Test Method No. 13. Test shall meet the requirements of Table 3 thru Table 8, as applicable. Double Shear Strength tests are not applicable to protruding head fasteners having a grip length less than two diameters and to flush head fasteners having a grip length less than two and one-half diameters. See sampling size as per Table 11.

4.5.6 Tensile Strength:

Tensile Strength tests shall be performed in accordance with NASM1312, Test Method No. 8, except load deflection curves are required for qualification tests only. Tensile Strength tests shall be conducted on bolts with (maximum) grip length equal to twice the nominal diameter or longer. Tensile Strength tests shall be performed in nominal grip condition (+/- .016"). Test shall meet the requirements of Table 3 thru Table 8, as applicable. Fixture clearance holes shall be used. See sampling size as per Table 11.

4.5.7 Tension Pre-load:

Tension Pre-load tests shall be performed using a Load Cell in accordance with NASM1312, Test Method No. 16. Tension Pre-load tests shall be performed in nominal grip condition (+1/32"/-1/64"). Fixture clearance holes shall be used. All bolt grips shall be subject to pre-load test. Test shall meet the requirements of Table 3 thru Table 8, as applicable. See sampling size as per Table 11.

4.5.8 Locking Torque:

The minimum locking torque shall be determined on an assembled fastener which has been driven in air to simulate maximum grip condition (See exception note below). One of the threaded components, either the nut or the screw, shall be retained in a vise or similar fixture to prevent it from rotating. The remaining threaded portion of the assembly shall then be rotated in the direction of disassembly with a torque wrench and the locking torque shall be recorded as the minimum reading of the torque wrench during the final 90° of the first revolution. The test shall be run at a rate slow enough to prevent an excessive increase in temperature of the fastener and axial forces applied to the torque wrench shall be no more than necessary to maintain engagement of the wrenching surfaces.

Exception: Locking torque reading shall not be considered a "true reading" when the locking feature locates itself over the screw break-groove. In such case, the minimum locking torque shall be determined on an assembled fastener which has been driven in air to simulate a grip condition where the nut locking feature positioned itself about three(3) turns away from the screw break groove.

TITLE

SPECIFICATION

PROCUREMENT SPECIFICATION FOR FASTENER

DCB1000

INTERNALLY THREADED, SELF-LOCKING

PAGE 19 OF 20

REVISION: "G"

DATE: 01-23-17

Monogram Aerospace Fasteners

5.0 PREPARATION FOR DELIVERY

5.1 Packaging:

Fasteners shall be packaged in such a manner as to assure they will not be damaged or exposed to undue weathering or harmful materials. Unless otherwise specified by buyer, packaging shall be as follows.

5.1.1 Unit Packaging:

A unit package may include fasteners of only one type, size, part number and lot number.

A unit package may contain a maximum of 100 pieces. Boxes conforming to any of the following specifications may be used:

Paperboard Folding, Specification PPP-B-566, Style II

Fiberboard Shipping, Specification ASTM-D-5118.

5.1.2 Shipment Packaging:

Unit packages of fasteners may be consolidated into large packages for shipment.

Packages for shipment must allow economical transportation and must conform to consolidated freight classification rules.

5.2 Marking:

Unless otherwise specified by buyer, marking shall be as follows:

Each unit container shall be durably and legibly marked to give the following minimum information:

Brief descriptive title, complete manufacturer's part number, assembly lot number, manufacturer's name or trade mark, quantity in container. In addition to the special marking specified, unit containers and shipping packages shall be marked in accordance with MIL-STD-129.

6.0 NOTES:

6.1 Intended Use:

Fasteners covered by this specification are intended for structural attachments in aerospace vehicles and associated accessories whenever access to one side of the joint is not adequate for the installation of conventional structural fasteners.

6.1.1 It is not intended that these fasteners be employed in applications requiring removal.

6.1.2 These fasteners are intended for applications where shear loads are the primary design consideration and any tensile loads are of secondary concern.

6.2 Installation Tools:

The fasteners covered by this specification should be installed with tools recommended by the fastener producer and in accordance with the producer's instructions.

TITLE	SPECIFICATION
PROCUREMENT SPECIFICATION FOR FASTENER	DCB1000
INTERNALLY THREADED, SELF-LOCKING	PAGE 20 OF 20
REVISION: "G"	DATE: 01-23-17